

Sales Code: NCG350

Barcode: 5056211868255

Brand: nuie

Description: Freya Pan, Cistern & Seat

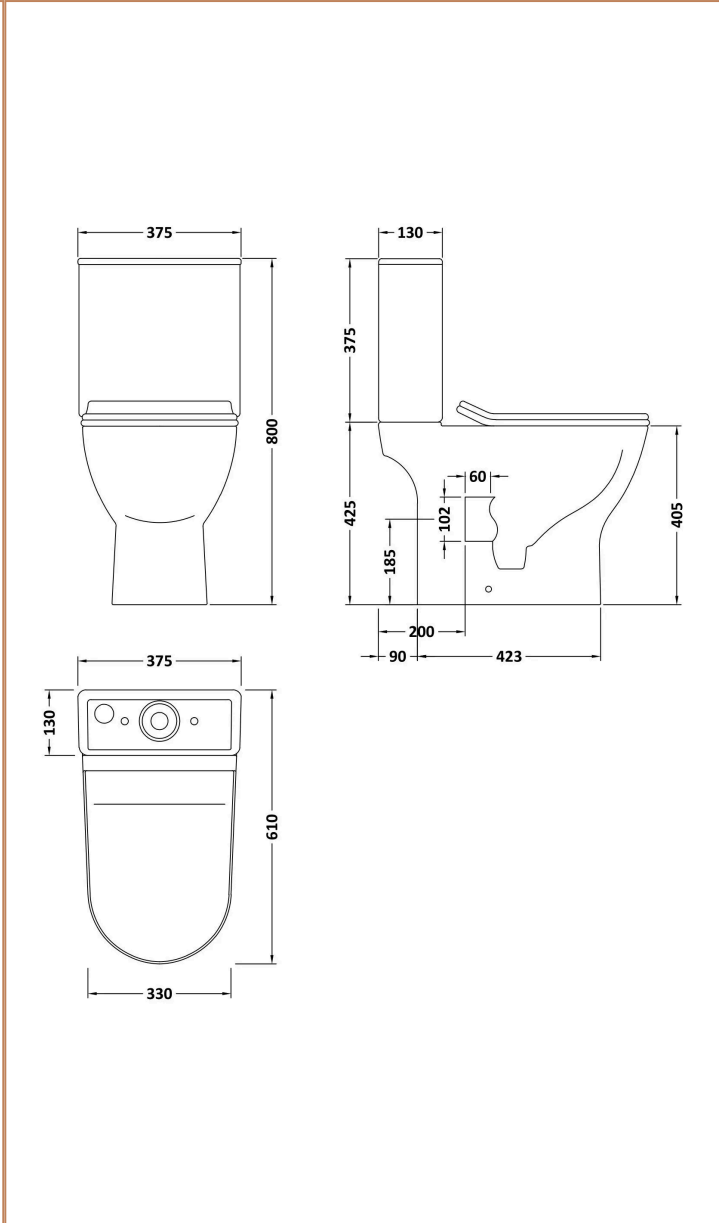

Product Dimensions

Product	800 x 375 x 610mm (H x W x D)
Packaged	435 x 770 x 420mm (H x W x D)
Nett Weight	33 kg
Packaged Weight	34 kg

Product Details

Country of Origin	China
Product Material	Vitreous China
Colour/Finish	White
Style	Contemporary
Includes Seat	Yes
Pan Type	Short Projection